



COM-5X

Electric Single Drum Research Winch

The COM-5X is a compact, lightweight, single drum research winch with variable speed electric motor drive and level-wind designed for use with industry standard CTD's, water sampling carousels, and payloads typically used on inshore and coastal research vessels.

WINCH SYSTEM SPECIFICATIONS

- ◆ Max. Drum Capacity: 2000M of 0.252 (6.5mm) cable.
- ◆ Max. Total Deck Lift: 800 lbs (364kg).
- ◆ Variable Speed Control: 0 to 67 meters/min cable speed.
- ◆ Electric Motor & Drive: 5 HP, AC-Variable frequency.
- ◆ Winch Control: Handheld pendant control pad on 25' cable (for remote control from a safe location).
- ◆ Power Requirements: 220VAC 3 Phase, 60Hz, 15A. Other source voltage options available.
- ◆ Approximate Weight: Without cable, 1,080 lbs (491kg).
- ◆ Winch Dimensions: 31.5" H x 47.8" W x 48.8" D.

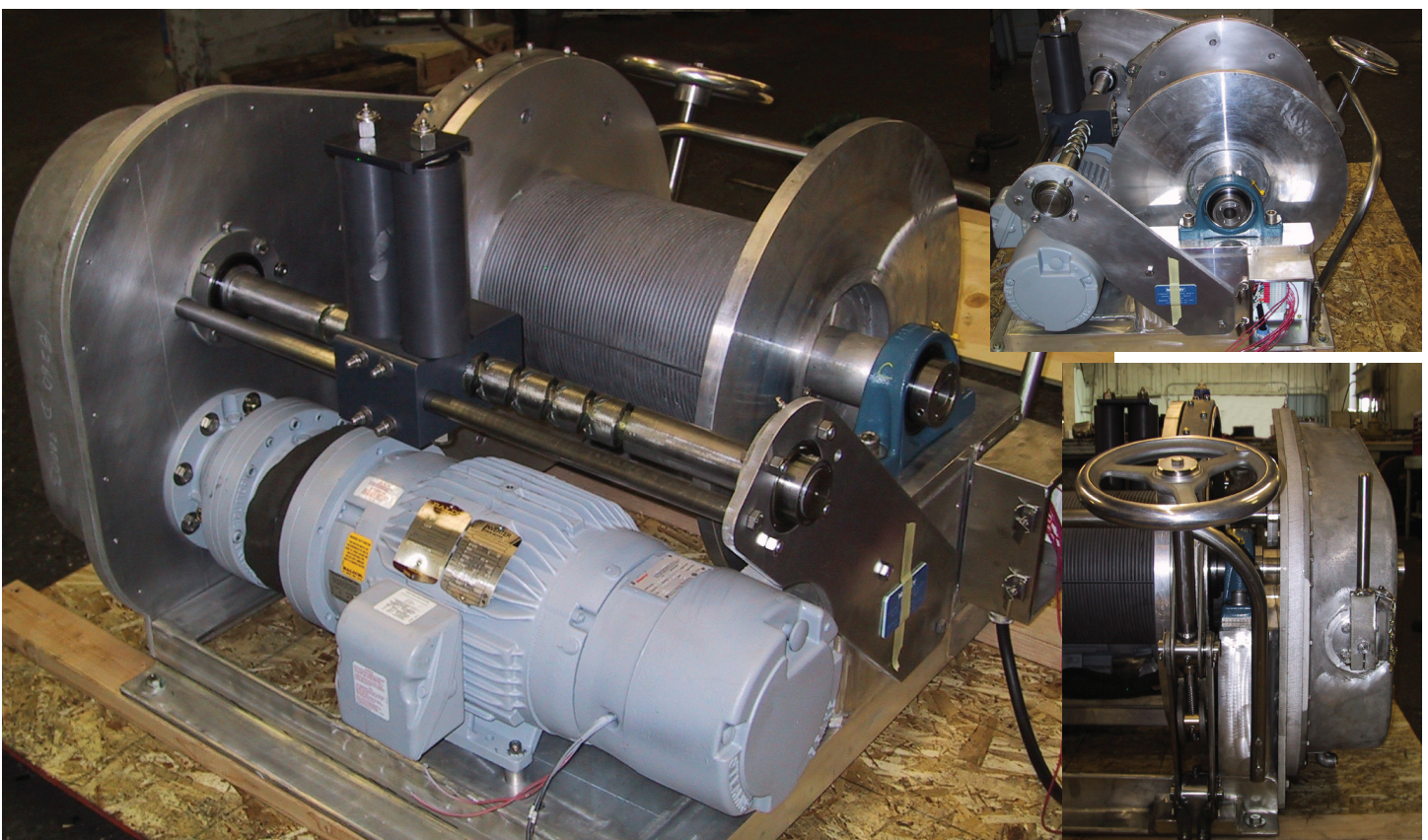

Markey Machinery Company, Inc.

7266 8th Avenue South, Seattle, WA 98108

Ph: (206) 622-4697 Toll Free: (800) 637-3430 Fax: (206) 623-9839

Email: info@markeymachinery.com

Represented by:

Griffin & Associates

355 Grow Avenue NW, Bainbridge Island, WA 98110 (USA)

Ph: (206) 595-9507 Email: bagriffin@griffinassociates.com



ISO 9001:2008 QMS

Represented by:

JH Menge & Company, Inc.

5825 Plouche Street, Harahan, LA 70123 (USA)

Ph: (504) 733-4871 Email: fclatour@jhmenge.com

Markey COM-5X Winch

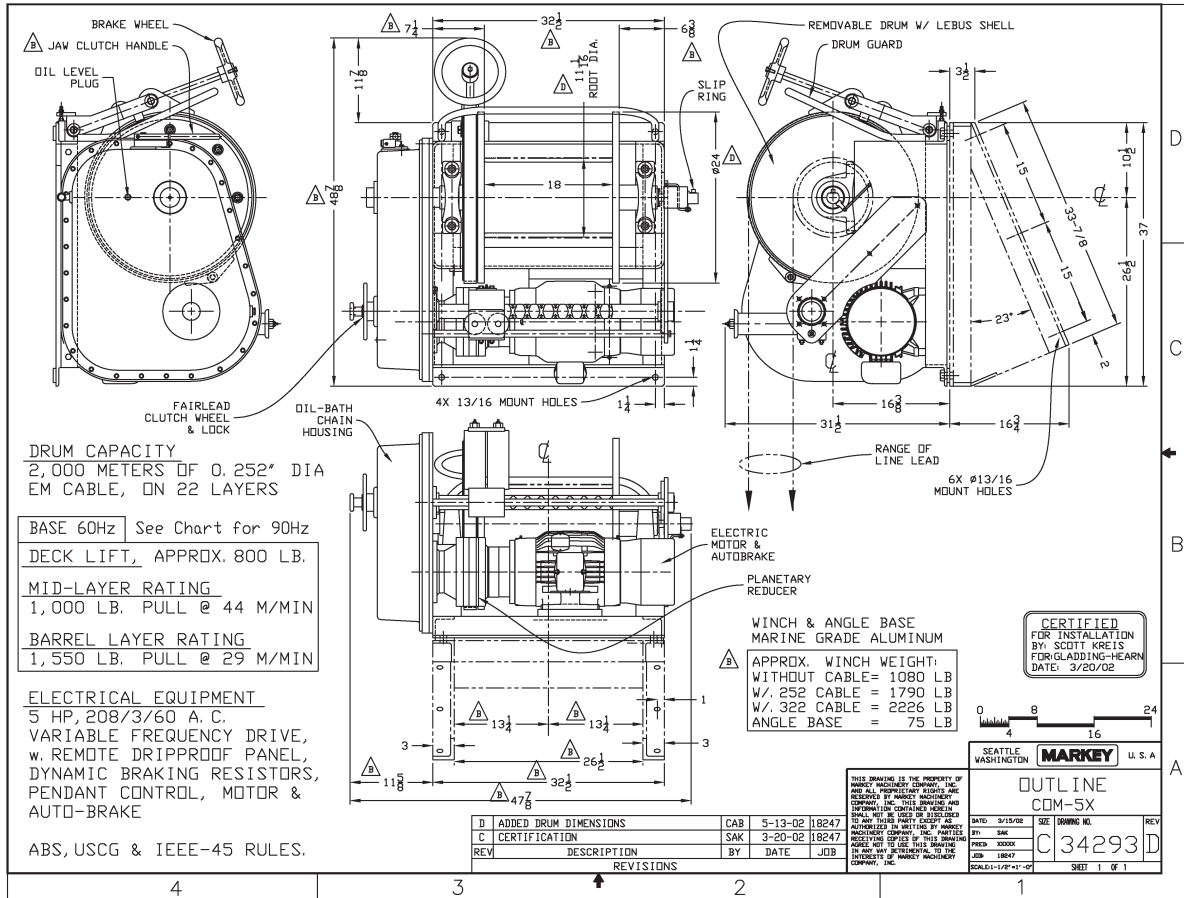

COM Winch System Options

- 3 HP, 5 HP, 7-1/2 HP, 10 HP, 15 HP electric versions available (hydraulic versions quoted on request)
- Versions available for a variety of source power configurations
- Performance ratings can be tailored to suit specific applications
- Other winch control systems available (pendant-type or joystick)
- Electro-Mechanical or fiber-optic slip-rings available
- Removable-drum option
- Manual band-brake and drum-disconnect clutch options
- Drum and level-wind can be configured to suit other cable sizes and capacity ratings
- Two-sheave level-wind option available for remote display of line-tension, line-speed, and scope-out
- Encoder-based option available for remote display of line-speed and scope-out only
- Markey can furnish cable, wire-rope, factory-spooling, and cable-termination services
- Steel or aluminum construction. Brushed-aluminum or other marine-duty surface finishes available

Markey's rugged, reliable COM winches are built to deepsea standards using materials and processes providing maximum life and minimum maintenance in marine and outdoor applications.

© 2011 MCo 18247



Anything Else is Just a Winch!