



# COM-4H

## Hydraulic Single Drum Research Winch

The COM-4H is a compact, lightweight, single drum research winch with variable speed hydraulic motor drive and level-wind designed for use with industry standard CTD's, water sampling carousels, and payloads typically used on inshore and coastal research vessels.

### WINCH SYSTEM SPECIFICATIONS

- ◆ Max. Drum Capacity: 400M of 0.322 diameter (8.2mm) EM cable.
- ◆ Max. Total Deck Lift: 1,800 lbs (381kg).
- ◆ Variable Speed Control: 0 to 70 meters/min cable speed.
- ◆ Hydraulic Motor: 26 cubic inch radial piston hydraulic motor, direct drive.
- ◆ Winch Control: Handheld pendant control pad on 25' cable (for remote control from a safe location).
- ◆ Power Requirements: 29 GPM (110 LPM) @ 2240 PSI (154 Bar) .
- ◆ Approximate Weight: Without cable, 309 lbs (140kg).
- ◆ Winch Dimensions: 20.4" H x 47.75" W x 29.3" D

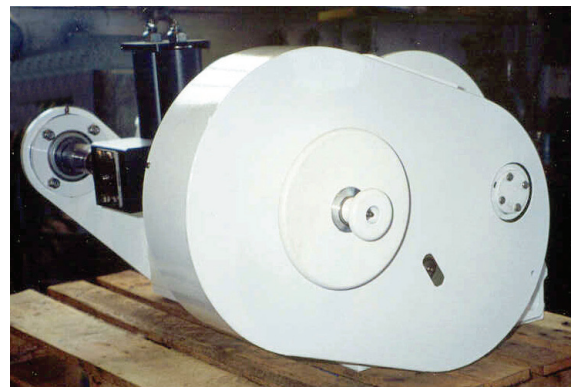
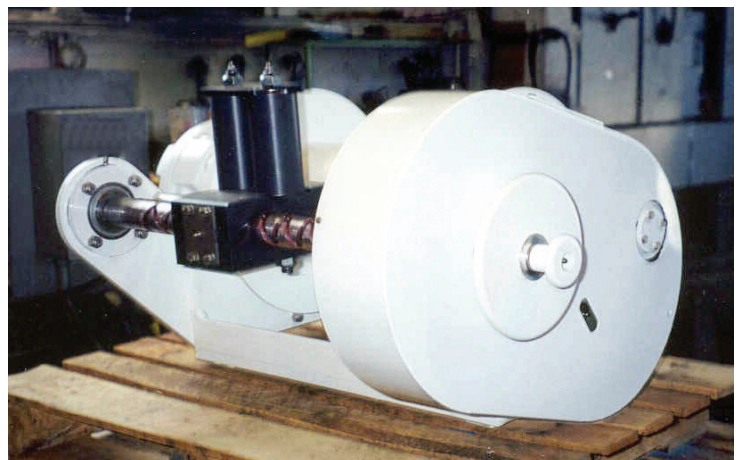

## Markey Machinery Company, Inc.

7266 8th Avenue South, Seattle, WA 98108

Ph: (206) 622-4697 Toll Free: (800) 637-3430 Fax: (206) 623-9839

Email: [info@markeymachinery.com](mailto:info@markeymachinery.com)

Represented by:

**Griffin & Associates**

355 Grow Avenue NW, Bainbridge Island, WA 98110 (USA)

Ph: (206) 595-9507 Email: [bagriffin@griffinassociates.com](mailto:bagriffin@griffinassociates.com)



ISO 9001:2008 QMS

Represented by:

**JH Menge & Company, Inc.**

5825 Plauche Street, Harahan, LA 70123 (USA)

Ph: (504) 733-4871 Email: [fclatour@jhmenge.com](mailto:fclatour@jhmenge.com)

# Markey COM-4H Winch

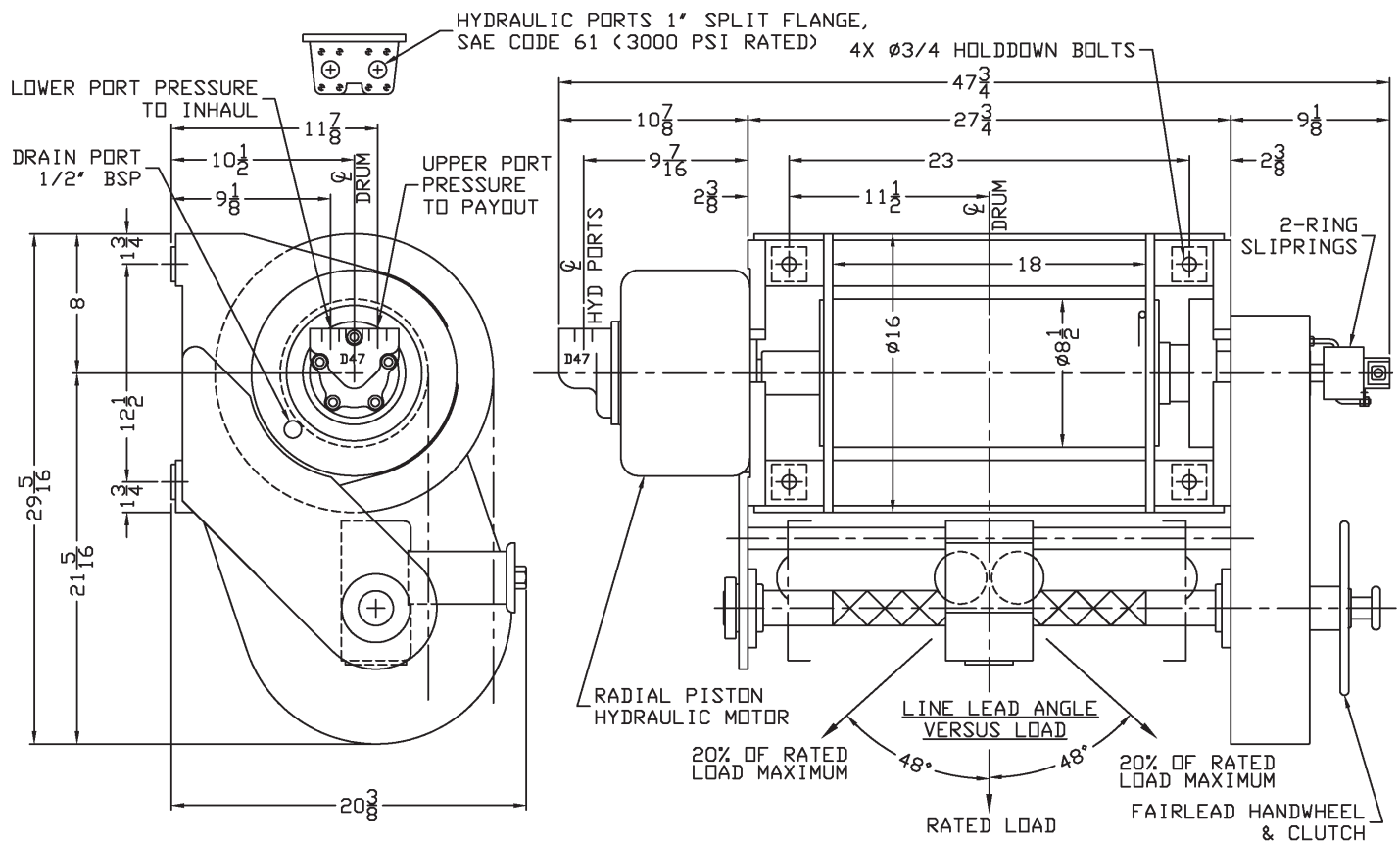

## COM Winch System Options

- ◆ 3 HP, 5 HP, 7-1/2 HP, 10 HP, 15 HP electric versions available
- ◆ Versions available for a variety of source power configurations
- ◆ Performance ratings can be tailored to suit specific applications
- ◆ Other winch control systems available (pendant-type or joystick)
- ◆ Electro-Mechanical or fiber-optic slip-rings available
- ◆ Removable-drum option
- ◆ Manual band-brake and drum-disconnect clutch options
- ◆ Drum and level-wind can be configured to suit other cable sizes and capacity ratings
- ◆ Two-sheave level-wind option available for remote display of line-tension, line-speed, and scope-out
- ◆ Encoder-based option available for remote display of line-speed and scope-out only
- ◆ Markey can furnish cable, wire-ropes, factory-spooling, and cable-termination services
- ◆ Steel or aluminum construction. Brushed-aluminum or other marine-duty surface finishes available

Markey's rugged, reliable COM winches are built to deepsea standards using materials and processes providing maximum life and minimum maintenance in marine and outdoor applications.

© 2011 MMCo 17565



*Anything Else is Just a Winch!*