



# DEPS-76AR

## Abandonment & Recovery Winch

The DEPS-76AR is designed with a 34:1 D:d ratio at the barrel layer which is significantly larger than competing designs. The larger D:d ratio reduces stress on the wire and enables the winch to spool 3,300m of 121mm wire rope in eight layers. By spooling in only eight layers, the winch is capable of 450Tm of line pull on all layers over the weight of the cable. In addition, the single-drum design reduces the frequency of bending fatigue cycles as compared to traction winches. A computer controlled fairlead ensures that wire is strategically spooled to minimize wire abrasion. The DEPS-76AR reduces wire wear and fits in a more compact footprint than competing designs.

### Winch System Specifications

- ◆ Max. Drum Capacity: 3,300 meters of 121 mm (4-3/4") diameter wire rope.
- ◆ Rated Performance: Up to 32 m/min (105 ft/min ) and up to 450 metric tons line-pull (on all layers).
- ◆ Electric Motor & Drive: 5 x 350 HP AC electric variable-frequency marine-duty motors with automatic brakes.
- ◆ Fairleader System: Designed for forces up to breaking strength of wire, includes auto-grease system.
- ◆ Winch Control: Closed loop line tension control, can be controlled from multiple operator stations.
- ◆ Power Requirements: 460 VAC 3 Phase, 60Hz. Other source voltage options available.
- ◆ Winch Dimensions: 6.25m H x 9.23m W x 10.18m D. Approx. Weight: 212 Metric Tonnes w/o wire.

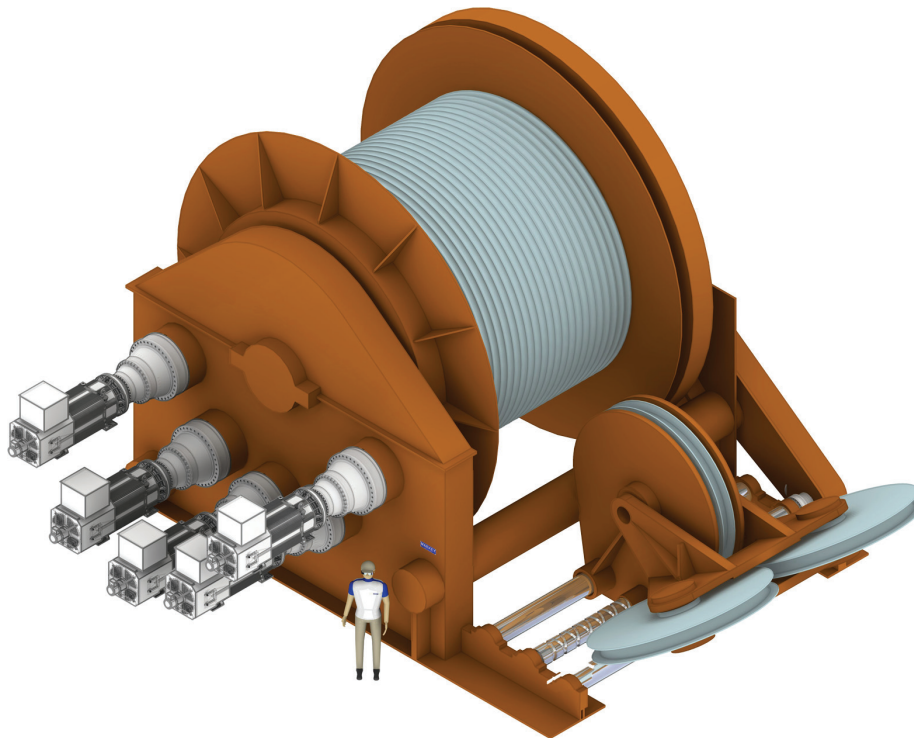

## Markey Machinery Company, Inc.

7266 8th Avenue South, Seattle, WA 98108

Ph: (206) 622-4697 Toll Free: (800) 637-3430 Fax: (206) 623-9839

Email: [info@markeymachinery.com](mailto:info@markeymachinery.com)

Represented by:

**Griffin & Associates**

355 Grow Avenue NW, Bainbridge Island, WA 98110 (USA)

Ph: (206) 595-9507 Email: [bagriffin@griffinassociates.com](mailto:bagriffin@griffinassociates.com)



Represented by:

**JH Menge & Company, Inc.**

5825 Plouche Street, Harahan, LA 70123 (USA)

Ph: (504) 733-4871 Email: [fcilatour@jhmenge.com](mailto:fcilatour@jhmenge.com)

# Markey DEPS-76AR Winch

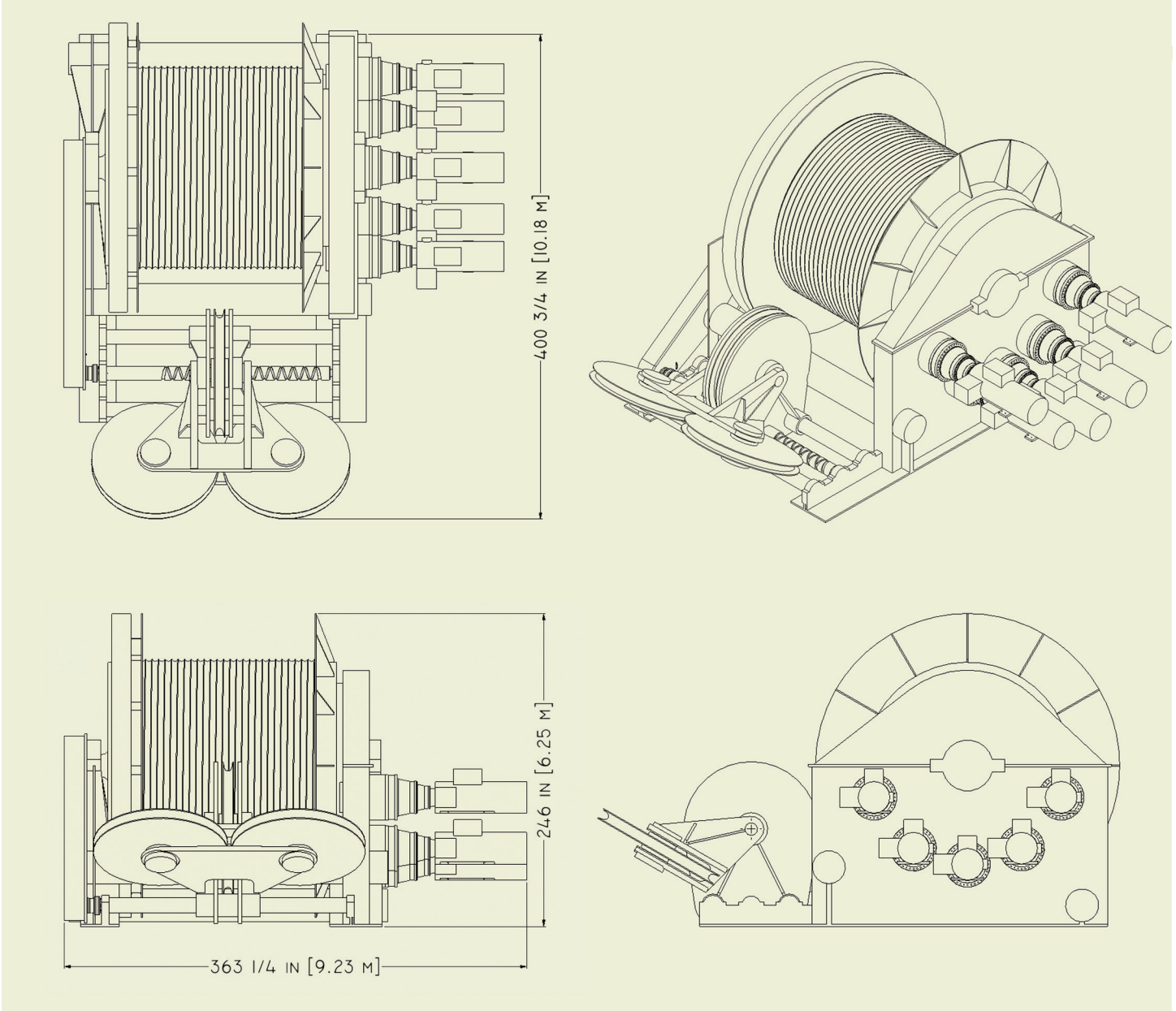

Markey's rugged winches are built to the highest quality workboat standards using materials and processes providing maximum life and minimum maintenance in marine and outdoor applications.

© 2011



*Anything Else is Just a Winch!*