



DEPGF-48-50HP

Electric Hawser Winch

The DEPGF-48-50HP is a single-drum electric hawser winch with warping head. It features automatic tension-selectable render/recover mode, high braking capacities, and fast line speeds for escort and ship-assist vessels. All electrical components comply with ABS, USCG, and IEEE-45 standards.

Winch System Specifications

- ◆ Drum Capacity: 400 feet / 122 meters - 9" circumference / 73 mm diameter synthetic line
- ◆ Performance: 26,900 lbs / 120 kN line pull - 275 feet per minute / 84 meters per minute
- ◆ Electric Motor & Drive: 50HP / 37kW marine-duty electric motor with AC-variable frequency drive
- ◆ Winch Braking: 400,000 lbs - 1779 kN
- ◆ Winch Control: Wheelhouse controls with on-deck emergency stop and freewheel pushbuttons
- ◆ Power Requirements: 460 VAC 3 Phase, 60Hz. Other source voltage options available.
- ◆ Weight: 30,000 lbs / 13608 kg

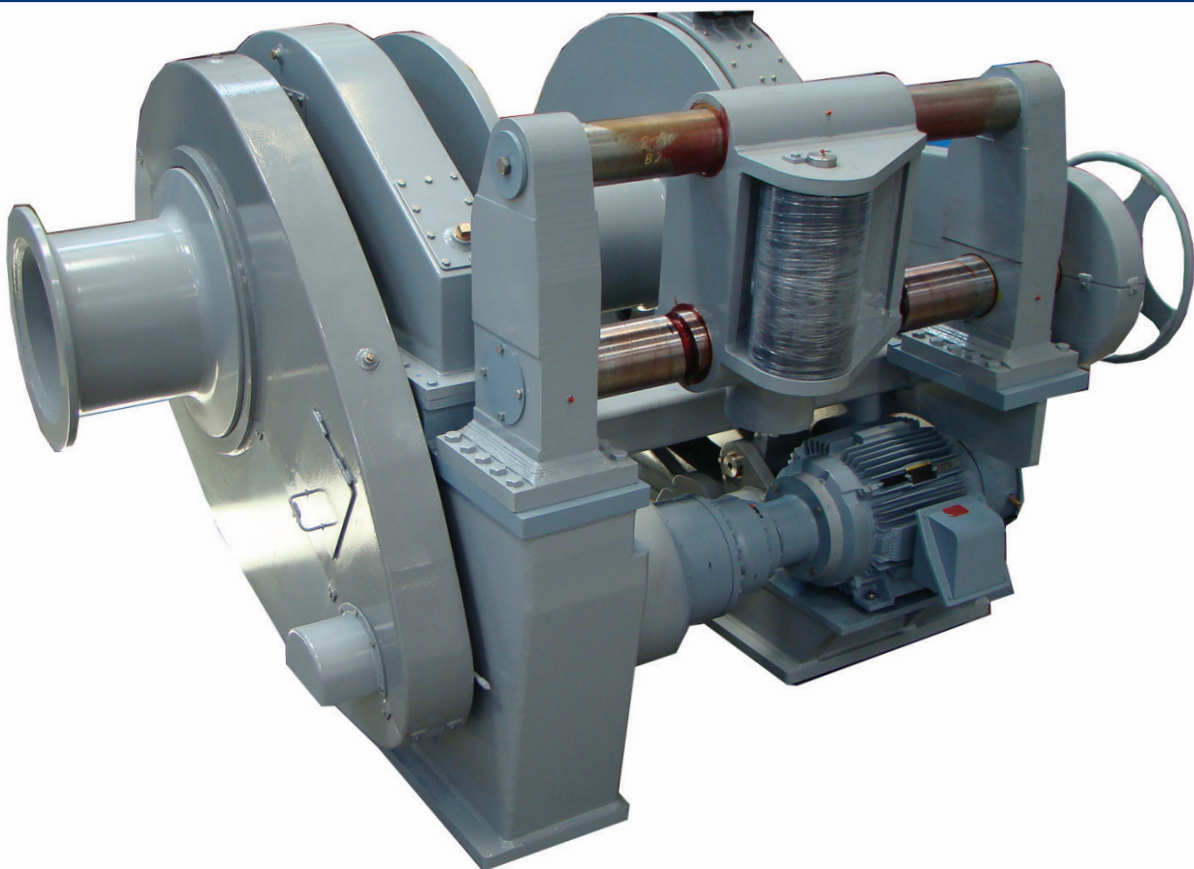

Markey Machinery Company, Inc.

7266 8th Avenue South, Seattle, WA 98108

Ph: (206) 622-4697 Toll Free: (800) 637-3430 Fax: (206) 623-9839

Email: info@markeymachinery.com

Represented by:

Griffin & Associates

355 Grow Avenue NW, Bainbridge Island, WA 98110 (USA)

Ph: (206) 595-9507 Email: bagriffin@griffinassociates.com

MARKEY

ISO 9001:2008 QMS

Represented by:

JH Menge & Company, Inc.

5825 Plouche Street, Harahan, LA 70123 (USA)

Ph: (504) 733-4871 Email: folatour@jhmenge.com

Markey DEPGF-48-50HP

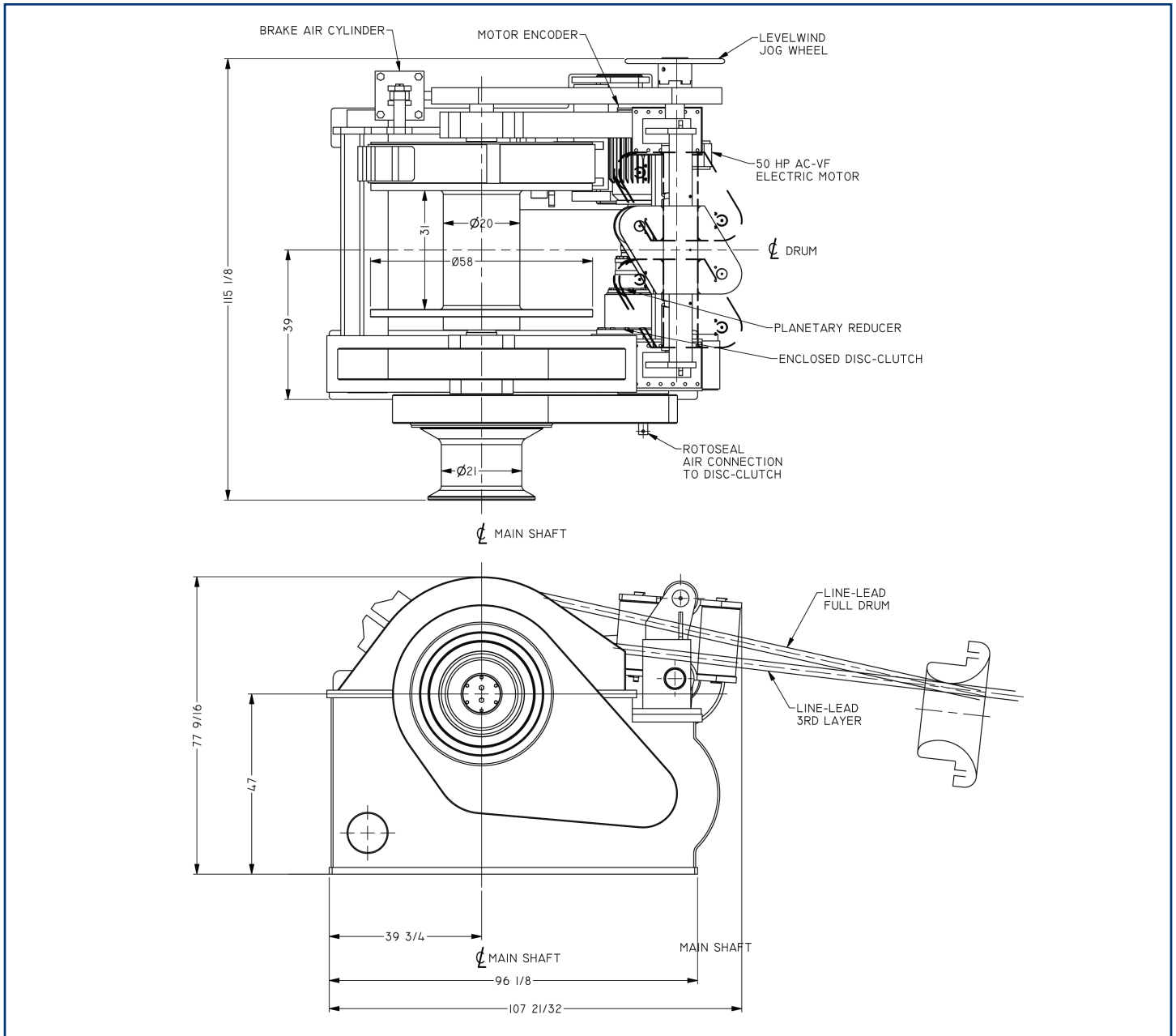

Hawser Winch System Options

- ◆ Digital/Analog Line Tension Display System
- ◆ Multiple Station Controls
- ◆ A variety of source power configurations can be accommodated
- ◆ Electrical hooks in system box for ship's UPS
- ◆ Performance ratings can be tailored to suit specific applications
- ◆ Other drum options are available

Markey's rugged winches are built to the highest quality workboat standards using materials and processes providing maximum life and minimum maintenance in marine and outdoor applications.

© 2011 MMCo 20965 v2



Anything Else is Just a Winch!