



TDSDS-36

Diesel Towing Winch

The TDSDS-36 is a rugged diesel-driven double-drum towing winch with warping head and towing drum, designed for the toughest offshore towing or anchor-handling applications. Built for high performance and low maintenance, the TDSDS-36 is an excellent choice for newbuild or retrofit projects, and can be counted on to provide decades of reliable service.

WINCH SYSTEM SPECIFICATIONS

◆ Max. Drum Capacity:	2,940 feet (towing drum) and 1,940 feet (auxiliary drum) of 2.5" wire rope.
◆ Rated Line-Pull:	Up to 348,000 lbs rated pull (stall). Light line speeds up to 97 ft/min at barrel layer.
◆ Diesel Power Unit:	Performance based on Cummins ISC 259 Diesel w/Allison CRT-5631 transmission.
◆ Winch Brakes:	600,000 lbs holding power (150 PSI air), with manual handwheel for lock-down.
◆ Winch Controls:	Two-station pneumatic for winch, engine, and transmission.
◆ Winch Dimensions:	95.3" H x 214.0" W x 184.6" D.
◆ Approximate Weight:	70,000 lbs.



Markey Machinery Company, Inc.

4634 East Marginal Way South, Suite C-140, Seattle, WA 98134

Phone: (206) 622-4697 Toll Free (800) 637-3430 Fax: (206) 623-9839

Email: info@markeymachinery.com

Represented by:

Griffin & Associates - 355 Grow Avenue NW, Bainbridge Island, WA 98110 (USA) Phone: 206-780-0509 Email: bagriffin@griffinassociates.com
JH Menge & Company, Inc - 5825 Plauche Street, New Orleans, LA 70123 (USA) Phone: 504-733-4871 Email: fcilatour@jhmenge.com

Markey TDSDS-36 Towing Winch

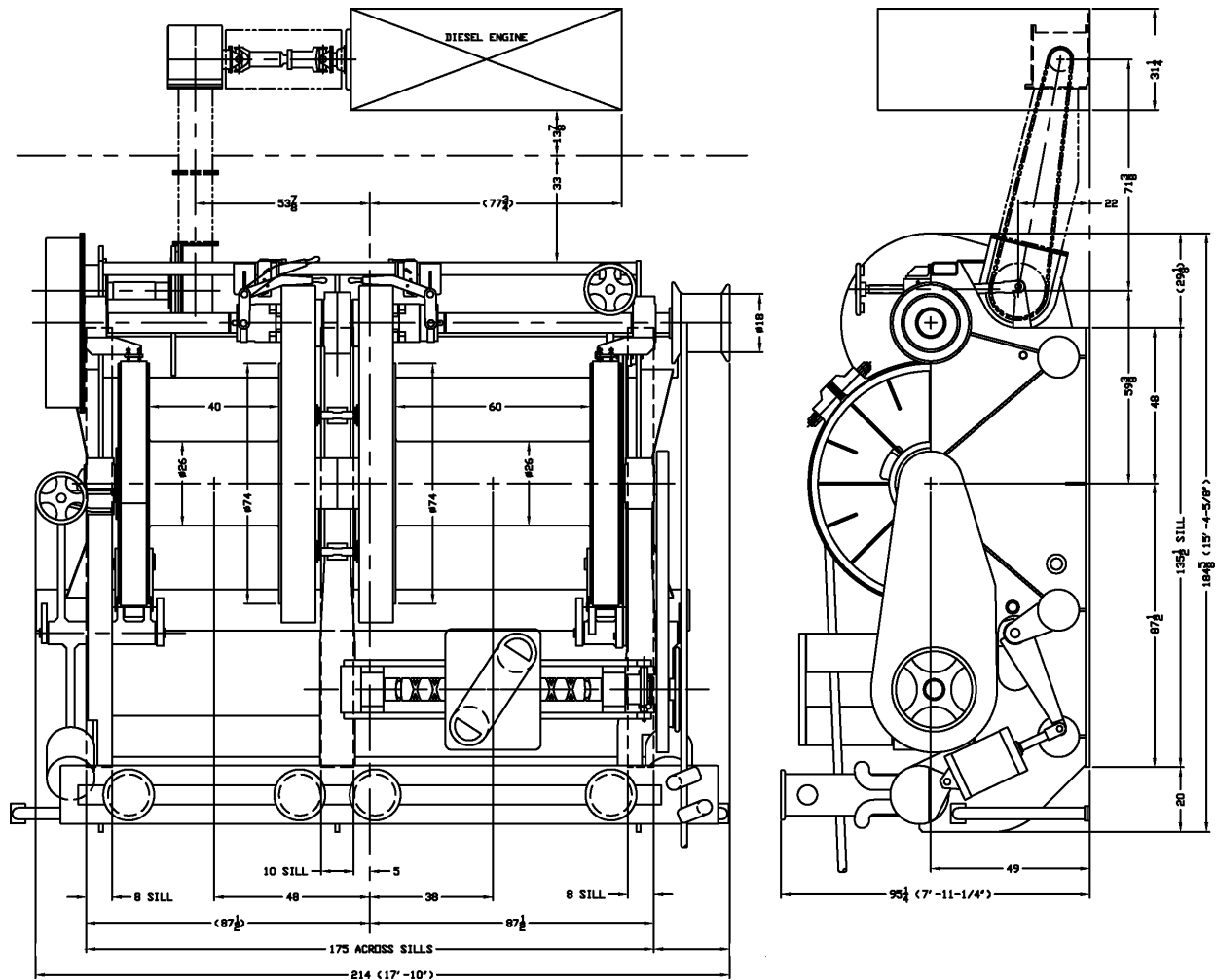

Towing Winch System Options

- ◆ Single & Double Drum configurations available
- ◆ Dual fairleads available
- ◆ Winch can be designed for chain-drive from Diesel Power Unit located below-deck or in the fidley
- ◆ Winch can be designed for shaft-drive from Diesel Power Unit located in the fidley
- ◆ Drum sizes can be changed to accomodate wire rope capacity requirements
- ◆ Auxiliary drum available to replace warping head
- ◆ Diesel, hydraulic & electric drives available
- ◆ Performance ratings can be tailored to suit specific applications
- ◆ 2nd and 3rd-station winch controls available
- ◆ Marine-duty epoxy paint system

Markey's rugged towing winches are built to the highest quality workboat standards using materials and processes providing maximum life and minimum maintenance in marine and outdoor applications.



Innovation you can depend on