



# TDSD-24WF

*Diesel "Waterfall" Towing Winch*

The TDSD-24WF is a reliable diesel-driven double-drum towing winch featuring a compact "waterfall" drum configuration. High line-pull and braking power makes it perfect for offshore towing or anchor-handling applications. Ruggedly built for low maintenance requirements and to provide decades of high performance, the TDSD-24WF is a true industry workhorse.

### WINCH SYSTEM SPECIFICATIONS

- ◆ **Max. Drum Capacity:** 2,800 feet of 1.5" wire-rope, or 2,350 feet of 1.75" wire-rope on each drum.
- ◆ **Rated Line-Pull:** 158,000 lbs rated pull (stall) at barrel layer, in first gear.
- ◆ **Diesel Power Unit:** Performance based on John Deere 4045TF (115HP) w/Funk Series 2000 Transmission
- ◆ **Winch Brakes:** Air-cylinder set and release, with manual handwheel provided for lock-down.
- ◆ **Winch Controls:** Pneumatic / Electric.
- ◆ **Winch Dimensions:** 100.0" H x 114.0" W x 154.0" D. **Approximate Weight:** 41,000 lbs.



## Markey Machinery Company, Inc.

4634 East Marginal Way South, Suite C-140, Seattle, WA 98134  
Phone: (206) 622-4697 Toll Free (800) 637-3430 Fax: (206) 623-9839  
Email: [info@markeymachinery.com](mailto:info@markeymachinery.com)

Represented by:

**Griffin & Associates** - 355 Grow Avenue NW, Bainbridge Island, WA 98110 (USA) Phone: 206-780-0509 Email: [bagriffin@griffinassociates.com](mailto:bagriffin@griffinassociates.com)  
**JH Menge & Company, Inc** - 5825 Plauche Street, New Orleans, LA 70123 (USA) Phone: 504-733-4871 Email: [fcletour@jhmenge.com](mailto:fcletour@jhmenge.com)

# TDSD-24WF Towing Winch

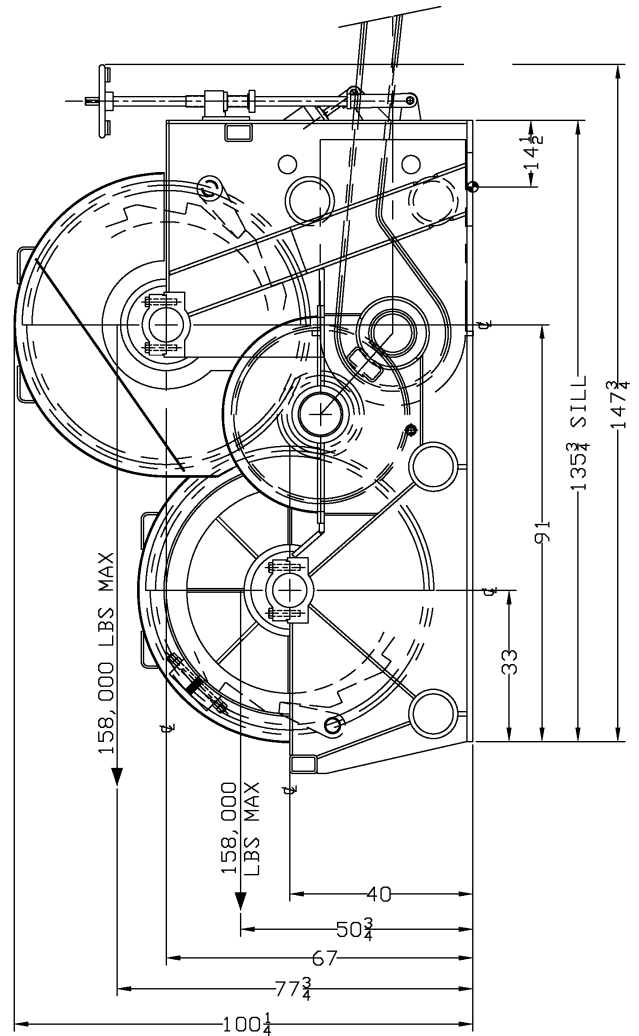
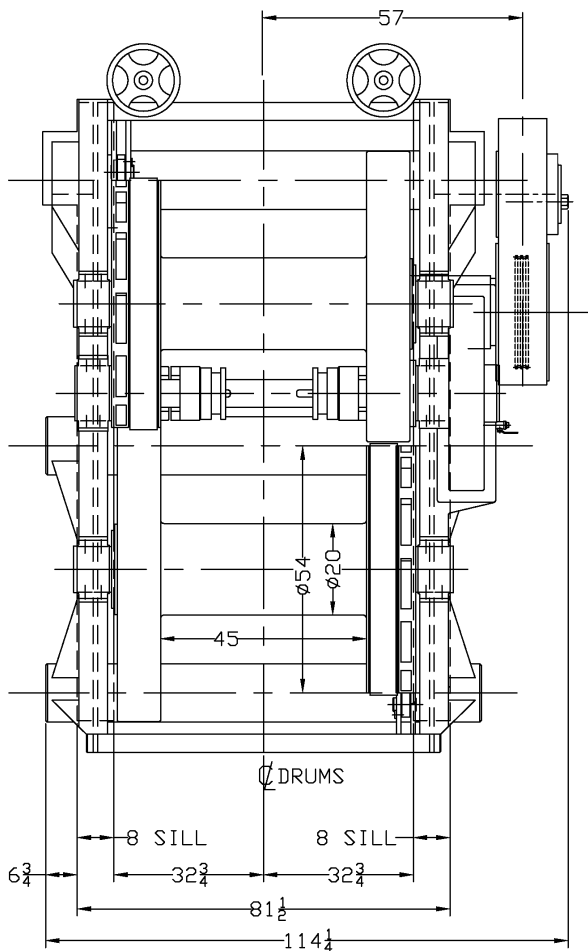

## Towing Winch System Options

- ◆ Single & Double Drum configurations available
- ◆ Dual fairleads available
- ◆ Winch can be designed for chain-drive from Diesel Power Unit located below-deck or in the fidley
- ◆ Winch can be designed for shaft-drive from Diesel Power Unit located in the fidley
- ◆ Drum sizes can be changed to accomodate various rope capacity requirements
- ◆ Auxiliary drum available to replace warping head
- ◆ Diesel, hydraulic & electric drives available
- ◆ Performance ratings can be tailored to suit specific applications
- ◆ 2nd and 3rd-station winch controls available
- ◆ Marine-duty epoxy paint system

Markey's rugged towing winches are built to the highest quality workboat standards using materials and processes providing maximum life and minimum maintenance in marine and outdoor applications.



*Innovation you can depend on*