



# DYSF-52

## Hydraulic Hawser Winch

The DYSF-52 is a hydraulic single-drum hawser winch with fairleader, featuring automatic render-recover mode, high braking capacity, and two speed ranges for escort and ship-assist vessels. Its simple, efficient, low-maintenance design delivers reliability and long service life.

### WINCH SYSTEM SPECIFICATIONS

- ◆ **Max. Drum Capacity:** Over 750 feet of 10.0" circumference synthetic line.
- ◆ **Rated Performance:** Two speed ranges: 33,800 lbs line-pull at 74 ft/min and 16,900 lbs line-pull at 148 ft/min
- ◆ **Hydraulic Motor & Drive:** Dual high-displacement radial-piston motors with freewheel capability. Gen-set driven hydraulic pumps, 110HP (64 GPM / 2600 PSI).
- ◆ **Winch Braking:** Dual band-type brakes, air set/released, 500,000 lbs minimum holding capacity.
- ◆ **Winch Control:** Wheelhouse controls with on-deck emergency stop and freewheel pushbuttons.
- ◆ **Power Requirements:** Generator-set front-end PTO to drive hydraulic pumps, or optional Electro-Hydraulic Power Unit.
- ◆ **Winch Dimensions:** 88.6" H x 112.6" W x 121.5" D. Approximate weight is 36,000 lbs.

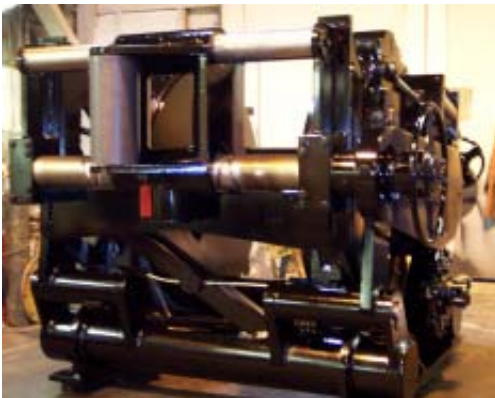

## Markey Machinery Company, Inc.

4634 East Marginal Way South, Suite C-140, Seattle, WA 98134

Phone: (206) 622-4697 Toll Free (800) 637-3430 Fax: (206) 623-9839

Email: [info@markeymachinery.com](mailto:info@markeymachinery.com)

Represented by:

Griffin & Associates - 355 Grow Avenue NW, Bainbridge Island, WA 98110 (USA) Phone: 206-780-0509 Email: [bagriffin@griffinassociates.com](mailto:bagriffin@griffinassociates.com)

JH Menge & Company, Inc - 5825 Plauche Street, New Orleans, LA 70123 (USA) Phone: 504-733-4871 Email: [fclatour@jhmenge.com](mailto:fclatour@jhmenge.com)

# Markey DYSF-52 Winch

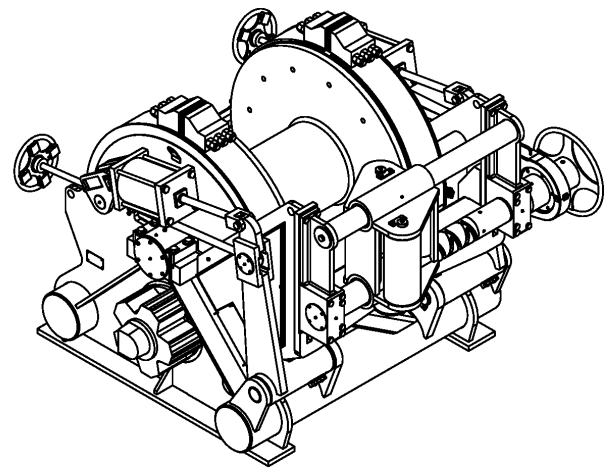
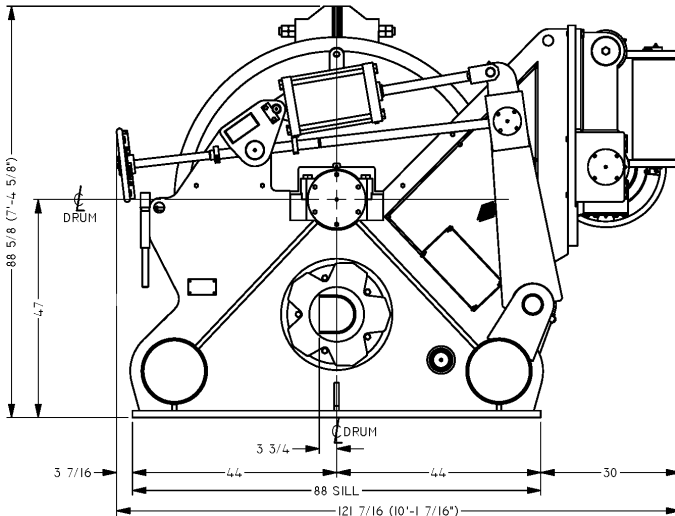
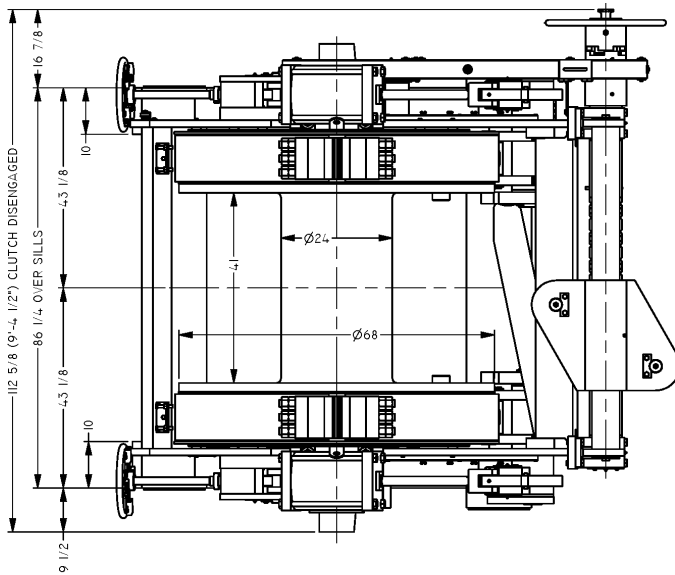

## Hawser Winch System Options

- ◆ Digital/Analog Line Tension Display System
- ◆ Multiple-station winch controls
- ◆ AC Variable frequency power systems and winch-drives available
- ◆ Models available with or without fairleader, and with or without warping head
- ◆ Proportional brake control available
- ◆ A variety of source power configurations can be accommodated
- ◆ Electrical hooks in system box for ship's UPS
- ◆ Performance ratings can be tailored to suit specific applications

Markey's rugged hawser winches are built to the highest quality workboat standards using materials and processes providing maximum life and minimum maintenance in marine and outdoor applications.



*Innovation you can depend on*