



DEPGF-42

Electric Hawser Winch

The DEPGF-42 is a single-drum electric hawser winch with warping head, used for escort and ship-assist applications. Includes automatic render/recover mode, high braking capacity, and fast line speeds. Electrical components meet all ABS, USCG, and IEEE-45 standards.

WINCH SYSTEM SPECIFICATIONS

- ◆ **Max. Drum Capacity:** 800 feet of 8" diameter Spectra/Plasma soft-line, plus one layer of 13" Nylon
- ◆ **Rated Line-Pull:** Up to 44,300 lbs.
- ◆ **Variable Speed Control:** Up to 366 feet/minute in light-line render/recover mode.
- ◆ **Electric Motor & Drive:** 75 HP marine-duty electric motor with AC variable frequency drive.
- ◆ **Winch Braking:** 400,000 lbs holding capacity, at second layer.
- ◆ **Winch Control:** Local and wheelhouse joystick control station, with line tension display system.
- ◆ **Power Requirements:** 460VAC 3 Phase, 60Hz. Other source voltage options available.
- ◆ **Approximate Weight:** 30,000 lbs.
- ◆ **Winch Dimensions:** 75.4" H x 136.5" W x 143.6" D.



Markey Machinery Company, Inc.

4634 East Marginal Way South, Suite C-140, Seattle, WA 98134
Phone: (206) 622-4697 Toll Free (800) 637-3430 Fax: (206) 623-9839
Email: info@markeymachinery.com

Represented by:

Griffin & Associates - 355 Grow Avenue NW, Bainbridge Island, WA 98110 (USA) Phone: 206-780-0509 Email: bagriffin@griffinassociates.com
JH Menge & Company, Inc - 5825 Plauche Street, New Orleans, LA 70123 (USA) Phone: 504-733-4871 Email: fclatour@jhmenge.com

Markey DEPGF-42 Winch

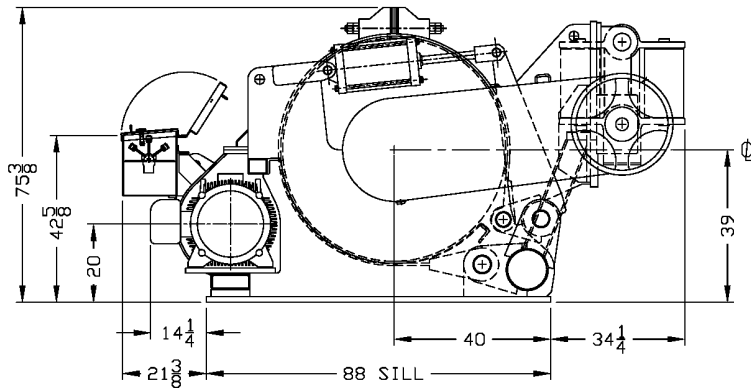
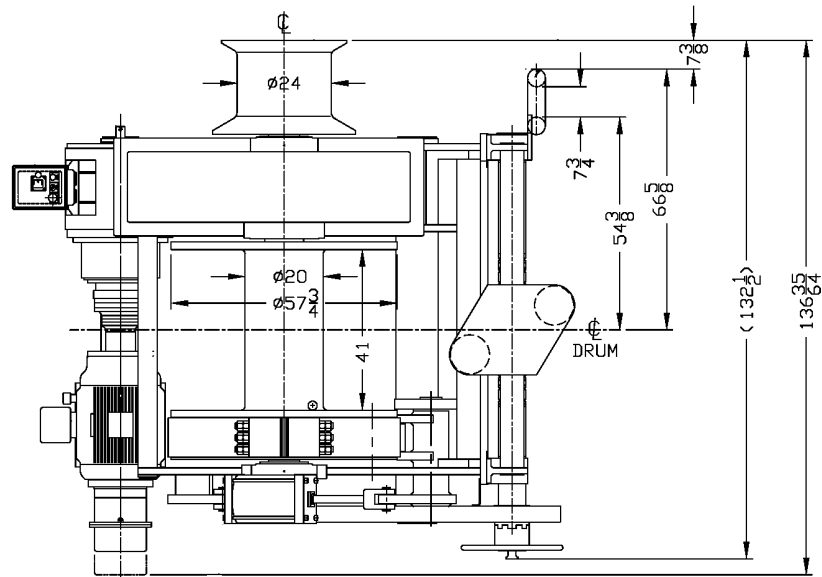

Hawser Winch System Options

- ◆ Electric or hydraulic drives available
(including options for explosion-proof electric motor, auto-brake, and intrinsically-safe controls)
- ◆ 40HP, 50HP, and 60HP models also available
- ◆ A variety of source power configurations can be accommodated
- ◆ Pushbutton freewheel mode manually engages or disengages the disk clutch
- ◆ Performance ratings can be tailored to suit specific applications
- ◆ Models available without fairleader
- ◆ Models available without warping head
- ◆ Marine-duty epoxy paint system with choice of colors

Markey's rugged hawser winches are built to the highest quality workboat standards using materials and processes providing maximum life and minimum maintenance in marine and outdoor applications.



Innovation you can depend on